



Wide-Format Inkjet Printer Cleaning Kit

The Wide-Format InkJet Printer Cleaning Kit was developed to ensure that the customer gets the best possible quality output from their printer at all times. The contents of this kit were developed based on the input from dealers and distributors worldwide. Included in the kit are the following items:

- Encoder strip cleaning tool
- Windex® cleaning solution
- Hand cleansing cream
- Lint-free wipes
- Cotton swabs
- Gloves



Encoder Strip Cleaning Tool

This tool was ergonomically designed to enable the encoder strip to be easily cleaned without fear of damaging it in the process.

The adjacent illustration shows how to correctly insert the cotton swab into the tool. **Note:** We do not recommend using any other type of cotton swab, in the provided tool, as they may not be as tightly packed and may leave debris on the encoder strip. Stand alone lint-free or foam swabs may be used independent of the encoder tool however.



To clean the encoder strip, insert the cotton swab into the tool as shown. It may take a little pressure to insert the swab in place, but this will ensure that it does not move when you are cleaning the encoder strip. Spray Windex directly onto cotton swab (do not spray near inkjet media). The shape of the tool allows easy cleaning of the encoder strip, both top and bottom. Because of the unique shape of the tool it will ensure that the cotton swab is perfectly parallel to the encoder strip and will effectively clean any ink

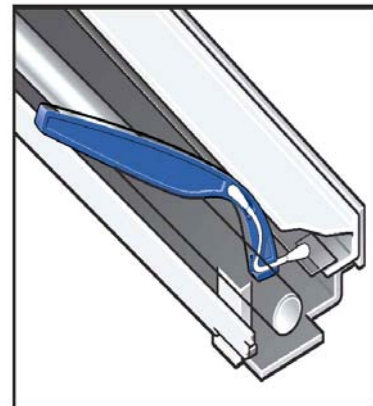

debris/spray from the encoder strip. Once you've cleaned the encoder strip with one or two full swipes of the swab, remove the cotton swab, replace with a new one, and repeat cleaning process again. It is strongly suggested to clean the printer a minimum of every 20 plot hours or weekly to ensure the printer stays clean. This will help prevent printer errors from occurring. Refer to product maintenance procedures or on-line technical bulletins for more information.

Windex Cleaning Solution

The Windex cleaning solution provides maximum cleaning capability without risk to the printer mechanics. The formula can be used to clean the majority of printer parts; it can be used on:

- Encoder strip
- Encoder sensor*
- Slide shaft
- Trailing cables
- Cartridge's rear electrical contacts
- Carriage flex driver cables (-illustration)
- Carriage paper sensor*
- Platen (printing) surface
- Cutter groove
- Covers and all metal areas of the unit
- Plastic parts

*Advanced customer cleaning procedure – refer to appropriate routine maintenance technical bulletin for instructions (i.e. Kodak 1200i TB3).

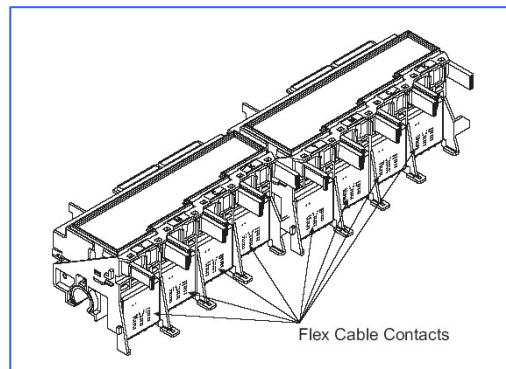

When using the Windex solution, apply a small amount of fluid to the lint-free cloth or the encoder strip cleaning tool cotton swab. Then, lightly clean the targeted area on the printer using the lint-free cloth or cotton swab.

Hand Cleansing Cream

The hand cleansing cream is to be used to clean hands of ink dye or stain.

Note: Gloves are provided to prevent getting hands dirty.

Wet the hands with water and shake off excess water. Apply a small amount of cream to hands and rub gently in small circles until ink dye/stain disappears. Repeat the procedure one more time if necessary.

